

Company Name	
Project Name	
Referance	



Design Criteria	
Medium	Water/glycol (max.%50)
Max. Flow velocity	1,5 m/s
Max. Flow rate	75 m3/h
Primary flow rate (Qp)	NA
Secondary flow rate (Qs)	NA
Max. Capacity (ΔT 20)	
Max. Pressure	10 barg
Max. Temperature	110°C
Pressure Drop at max.flow	4,2 kPa
Design Standard	EN 13445

**SC-V-M DN125 ViraPlus -
Air and Dirt Separators With Magnet
NRF nr. 8560965**

Testing and Quality Assurance	
Pressure Test (bar)	15 bar
Medium Test	Water
Test certificate	no
Design and manufacturing acc.2014/68/EC	yes art.4.3/SEP
Material certificates (structural parts)	no
Drawing	no
Weld procedures	no
Nondestructive testing (X-ray: 10%)	no
Notified body inspection	no

Technical Drawing

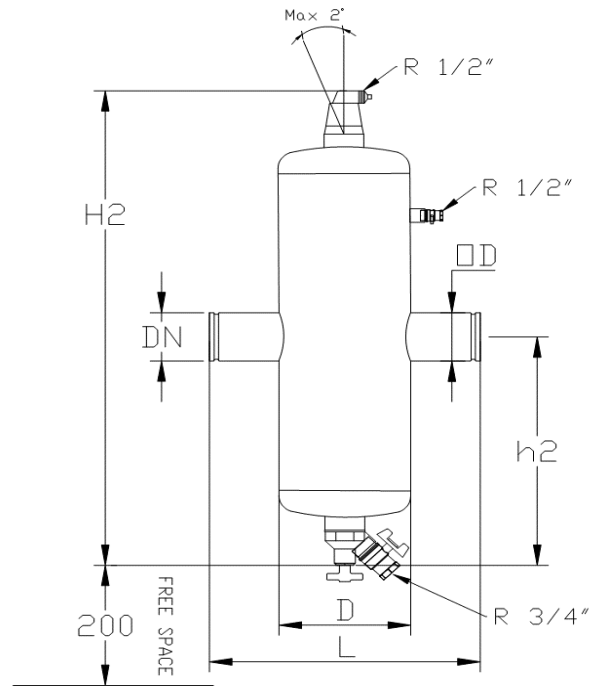

Construction Materials	
Body	S235 JR G2 (ST 37)
Connections	S235 JR G2 (ST 37)
Fittings	S235 JR G2 (ST 37)
Groved End	S235 JR G2 (ST 37)
Heads	S235 JR G2 (ST 37)
Deaeration cap	Brass
Valve sealing	EPDM
Float	PP
Internal mesh	316 Stainless Steel
Wire for magnet	316 Stainless Steel
Solder	Soft
Paint	Electrostatic
Color	Blue (RAL 5002)
Drain valve	Brass
Magnet	Neodymium

Dimension

DN	DN125/300
OD	139,7 mm
H2	1158 mm
h2	545 mm
L	615 mm
D	323,9 mm
Flow	
Volume	70 lt
Weight	45 kg

Products produced before 19.07.2016 are according to 97/23/EC

