

Company Name	
Project Name	
Reference	



Design Criteria	
Medium	Water/glycol (max.%50)
Max. Flow velocity	1,5 m/s
Max. Flow rate	12,0 m3/h
Primary flow rate (Qp)	NA
Secondary flow rate (Qs)	NA
Max. Capacity (ΔT 20)	
Max. Pressure	10 barg
Max. Temperature	110°C
Pressure Drop at max.flow	3 kPa
Design Standard	EN 13445

**SC-F-M DN50 ViraPlus -
Air and Dirt Separators With Magnet
NRF nr. 8560941**

Testing and Quality Assurance	
Pressure Test (bar)	15 bar
Medium Test	Water
Test certificate	no
Design and manufacturing acc.2014/68/EC	yes art.4.3/SEP
Material certificates (structural parts)	no
Drawing	no
Weld procedures	no
Nondestructive testing (X-ray: 10%)	no
Notified body inspection	no

Technical Drawing

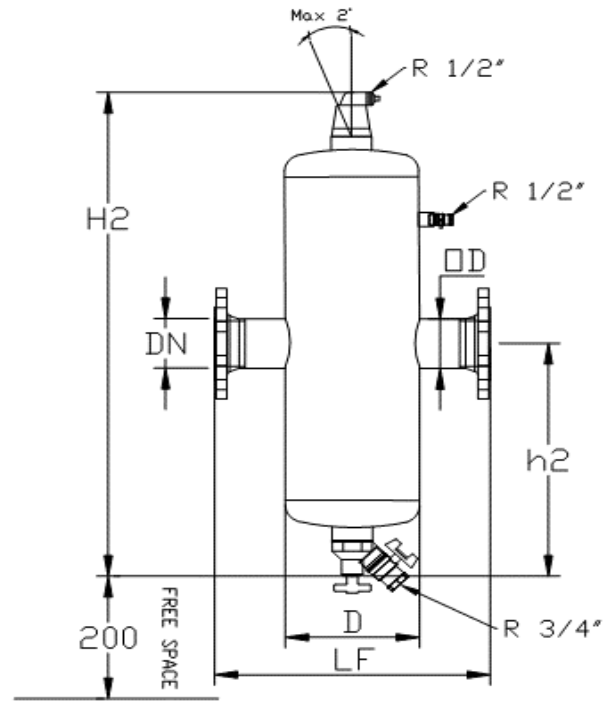

Construction Materials	
Body	S235 JR G2 (ST 37)
Connections	S235 JR G2 (ST 37)
Fittings	S235 JR G2 (ST 37)
Grooved End	S235 JR G2 (ST 37)
Heads	S235 JR G2 (ST 37)

Dimension

Deaeration cap	Brass	DN	DN50/150
Valve sealing	EPDM	OD	60,3 mm
Float	PP	H2	726 mm
Internal mesh	316 Stainless Steel	h2	330 mm
Wire for magnet	316 Stainless Steel	LF	350 mm
Solder	Soft	D	168,3 mm
Paint	Electrostatic	Flow	
Color	Blue (RAL 5002)	Volume	10 lt
Drain valve	Brass	Weight	18 kg
Magnet	Neodymium		

Products produced before 19.07.2016 are according to 97/23/EC